



# MILLGRAIN MACHINERY INDUSTRIES

**LOADER  
&  
UN-LOADER MACHINARIES**





# MILLGRAIN TRUCK LOADER



## MG-TL-01

### Technical Specification

<b>Capacity</b>	<b>As per Requirement</b>
<b>Material</b>	<b>Aluminium, Mild Steel, Stainless Steel</b>
<b>Operating Speed</b>	<b>Customized</b>
<b>Length</b>	<b>As per Requirement</b>
<b>Belt Width</b>	<b>As per Requirement</b>
<b>Design</b>	<b>Standard, Customized</b>
<b>Colour</b>	<b>Any</b>
<b>Condition</b>	<b>New</b>

- ✦ Very smooth conveyence
- ✦ Easy Towable Transport
- ✦ Less time consumption
- ✦ Man power reduction
- ✦ Many more

### Description:

We have leading specialization in manufacturing of **Truck Loader-Unloader Mobile Conveyor** unit for all application like for boxes, cartons, bags, etc. in warehouse, bottling plants, distilleries etc. and any places where material needs to be moved rapidly & efficiently. This conveyor is mostly reduce maximum labour & save time. These conveyor features are easy movability, slider bed design, zero maintenance.

#### Application:

Truck Loader Conveyor widely used for loading and unloading of bags, carton boxes in various industries. Widely used in sugar industries, distilleries, pharmaceuticals , packaging industries, warehouses, etc.



# MILLGRAIN BELT CONVEYORS

## MG-BC-01



### Technical Specification

<b>Capacity</b>	<b>As per Requirement</b>
<b>Material</b>	<b>Aluminium, Mild Steel, Stainless Steel</b>
<b>Operating Speed</b>	<b>Customized</b>
<b>Length</b>	<b>As per Requirement</b>
<b>Belt Width</b>	<b>As per Requirement</b>
<b>Design</b>	<b>Standard, Customized</b>
<b>Colour</b>	<b>Any</b>
<b>Condition</b>	<b>New</b>

- ✦ Very smooth conveyence ✦ Man power reduction
- ✦ Easy Towable Transport ✦ Many more
- ✦ Less time consumption

### Description:

We specialize in manufacturing qualitative range of belt conveyor which find wide application in various fields to move diverse unit loads & bulk materials. Our conveyors are highly in demand in mining operation, foundries, bagasse handling in co-generation plants granaries, coal handling plants, bag handling in sugar godowns and packing industries. They are used in handling loads from one location to another within the process in line production. The belt conveyors are easily adapted to the natural contour of the ground and can be operated over long distance. Entire assortment of the conveyors is characterized with:

### Application:

Belt Conveyor widely used for loading and unloading of bags, carton boxes in various industries. Widely used in sugar industries, distilleries, pharmaceuticals, packaging industries, warehouses.



# MILLGRAIN SCREW CONVEYORS

## A Wide Choice of Standard Parts

You get the system you need to solve your problem - yet keep cost at a minimum. Select the type of component from our standard line that fits your needs. For special flying designs to solve a particular problem.

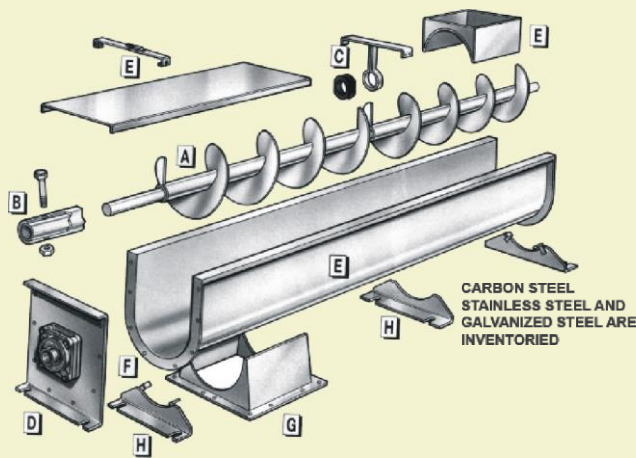

## MG-SC- 11



## Technical Specification

<b>Material</b>	<b>Stainless Steel</b>
<b>Size</b>	<b>50mm Dia to 1250 Dia</b>
<b>Design</b>	<b>Standard, Customized</b>
<b>Colour</b>	<b>Any</b>
<b>Condition</b>	<b>New</b>

## Description:

We have with us, Screw Conveyors that are widely used in both horizontal and vertical applications for conveying variety of material. Available in several designs, colors, shapes and sizes, these conveyors are fabricated using premium raw material to ensure quality. Very effective and economical for conveying granular material like plastic and cereals, these conveyors are covered by jacket with a high quality of metal to keep the conveyed material free from any kind of dust.

## Application:

Screw conveyors available in size form 50mm diameter to 1250mm diameter in variable pitch form mild steels & stainless steels with hard facing.

- ✦ Very smooth conveyence ✦ Man power reduction
- ✦ Easy Towable Transport ✦ Many more
- ✦ Less time consumption



## **Millgrain Machinery Industries**

**Reg Off: No. 312, Arani Main Road, Thuthipattu, Vellore-632011, Tamilnadu, India**

**Mobile: (+91) 8778201289 / (+91) 8105566637**

**E-mail: [millgrain2000@gmail.com](mailto:millgrain2000@gmail.com)  
[kumarvinayagam79@gmail.com](mailto:kumarvinayagam79@gmail.com)**

**Website: [Www.millgrain.in](http://www.millgrain.in)**