



**MILLGRAIN
MACHINERY INDUSTRIES**

BUILD

YOUR

FUTURE

RICE PROCESSING MACHINES

MLLGRAIN PADDY CLEANER

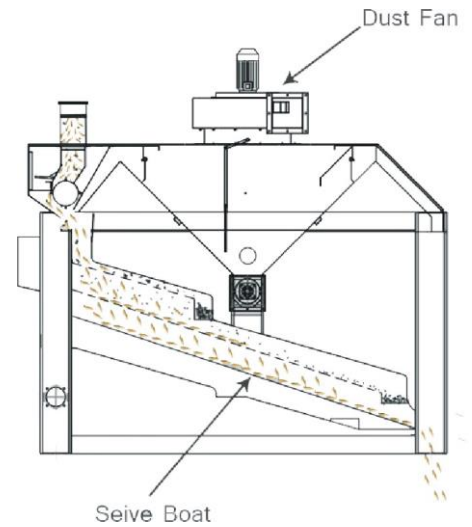

Name : Millgrain Paddy Cleaner
Capacity : 3-5 T Paddy / hr
Power : 2 HP
Blower : 5 HP
Voltage : 415 V

Name : Millgrain Paddy Cleaner
Capacity : 6-8 T Paddy / hr
Power : 3 HP
Blower : 7.5 HP
Voltage : 415 V

Paddy Wheat Features

- ✦ Corrosion free screen made up of G I
- ✦ Separation is carried out in different stages
- ✦ Designed with sound and dust proof technology for
- ✦ Pollution control Integrated Compact Unit

MILLGRAIN CLASSFIRE



Applications

- ✦ Raw Rice
- ✦ Boiled Rice
- ✦ Steamed Rice
- ✦ Basmati Rice

Features

MILLGRAIN Cleaning machine can efficiently separate oversized and undersized impurities from food grains. The machine can also be used grading different sizes of a product. The inbuilt Self-clean systems ensure optimum efficiency during the production cycle.

- ✦ Precise screens ensure High separating efficiency
- ✦ Capacities ranging from 3TPH - 12TPH
- ✦ Dust free operation
- ✦ Rodust construction with low maintenance
- ✦ Angle controller to adjust angle of throw

Machine Type	RCLA1		RCLC1		RCLB1		RCLD1
Capacity Ton/hour with precleaner	Medium Grain 6-8	Long Grain 4-5	Medium Grain 6-8	Long Grain 4-5	Medium Grain 8-12	Long Grain 5-8	-
Capacity (Ton/hour) For Rice	-		-		-		2-3
Vibromotor Power (Hp/Kw)	0.50/0.37 – 2 Nos		0.50/0.37 – 2 Nos		1/0.75 – 2 Nos		0.50/0.37 – 2 Nos
Voltage (V) Frequency(Hz)	415/50		415/50		415/50		415/50
Aspiration (CMM)	90		90		135		90
Weight (KG)	650		780		1300		740
Over All Size LxWxH (MM)	2659x1482x1674		2632x1502x1662		2659x1998x1729		2752x1482x1643

MILLGRAIN DE - STONER

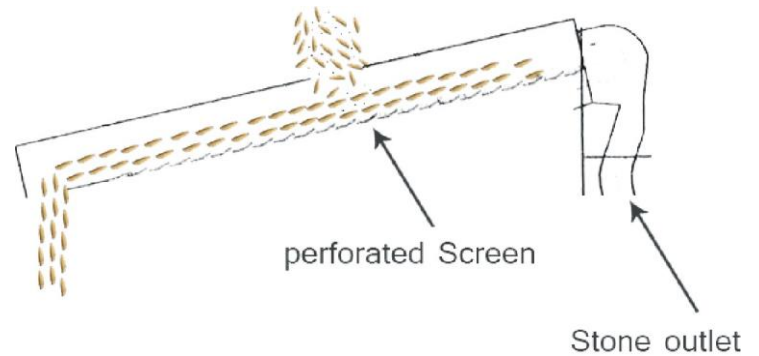

Applications

- ✦ Paddy
- ✦ Wheat

Features

- ✦ Efficient & Precise separation of stones
- ✦ Provided with closed circuit aspirator
- ✦ Sturdy, Rigid and Heavy duty construction
- ✦ Robust construction to withstand high vibration

Name : MILLGRAIN DE-STONER
Capacity : 3.0 T Paddy / hr
Power : 1.5 HP
Aspirations : 70' / min
Voltage : 415 V

Name : MILLGRAIN DE-STONER
Capacity : 5.0 T Paddy / hr
Power : 2 HP
Aspirations : 80' / min
Voltage : 415 V

MILLGRAIN PNEUMATIC SHELLER

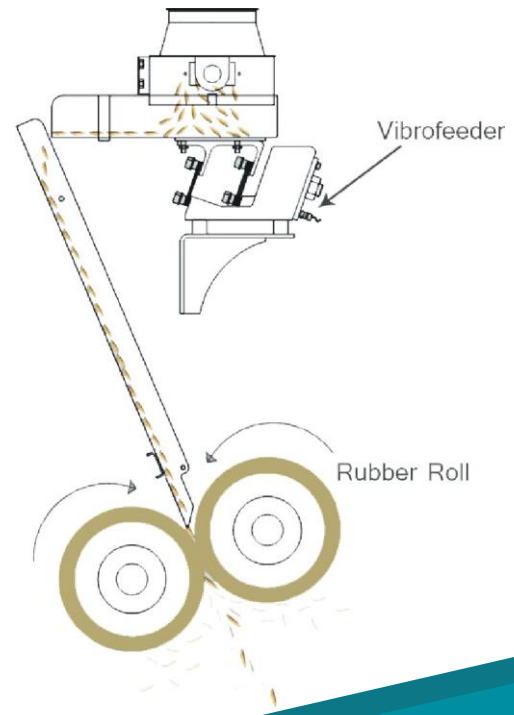

Applications

- ✦ Raw Rice
- ✦ Boiled Rice
- ✦ Steamed Rice
- ✦ Basmati Rice

Features

- ✦ High end Technology Vibro - feeder used to feed the paddy grains at required angle into the threshing rollers

- ✦ Maximum life for paddy threshing rollers
- ✦ Sturdy double inlet cooling blower provided
- ✦ Very very low noise while shelling of paddy

Name : MILLGRAIN PNEUMATIC SHELLER

Capacity : 3.0 T Paddy / hr

Power : 10 HP

Aspirations : 5m' / min

Voltage : 415 V

Name : MILLGRAIN PNEUMATIC SHELLER

Capacity : 5.0 T Paddy / hr

Power : 15 HP

Aspirations : 5' / min

Voltage : 415 V

MILLGRAIN PADDY SEPERATOR

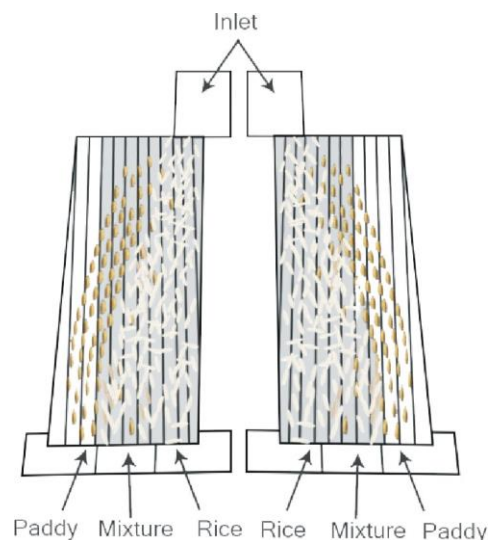

Applications

- ✦ Raw Rice
- ✦ Boiled Rice
- ✦ Steamed Rice
- ✦ Basmati Rice
- ✦ Parboiled Rice

Features

This machine specilay designed for high capacity and efficiently paddy and Brown rice

- ✦ High Yield and Strong Separation
- ✦ Compact Structure and Smooth Operation
- ✦ Advanced Automation Technology

Name : MILLGRAIN PADDY SEPERATOR

Capacity : 3.0 T Paddy / hr

Power : 4 HP

No. Of Tray : 20 x 2

Voltage : 415 V / 50 Hz

Name : MILLGRAIN PADDY SEPERATOR

Capacity : 4.0 T Paddy / hr

Power : 4 HP

No. Of Tray : 20 x 2

Voltage : 415 V / 50 Hz

MILLGRAIN RICE POLISHER

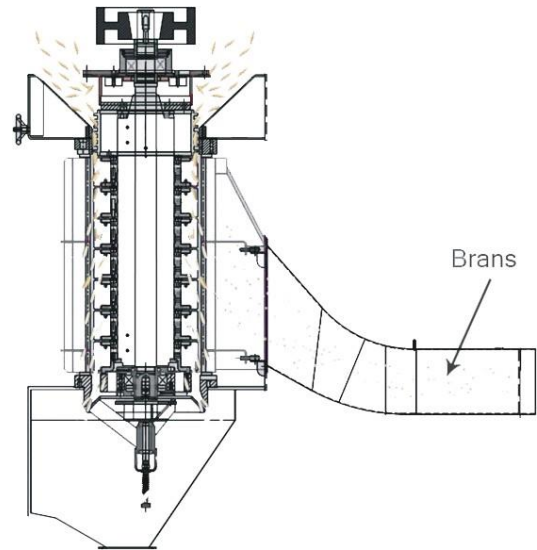

Applications

- ✦ Raw Rice
- ✦ Boiled Rice
- ✦ Steamed Rice
- ✦ Basmati Rice

Features

- ✦ Specially designed Silicon carbide grinding wheels
- ✦ Compact Structure
- ✦ Very high degree of polish
- ✦ Maintenance free
- ✦ Easy polish adjustment mechanism

Name : MILLGRAIN RICE POLISHER

Capacity : 3.0 T / hr

Power : 25 HP

No of abrasive wheels : 6 nos.

Voltage : 415 V / 50Hz

Abrasive Wheel : 16/24/30/36 grit
grit

Name :MILLGRAIN RICE POLISHER

Capacity : 5.0 T / hr

Power : 50 HP

No of abrasive wheels : 7 nos.

Voltage : 415 V / 50Hz

Abrasive Wheel: 16/24/30/36 grit
grit

MILLGRAIN RICE SHIFTER



Applications

- ✦ Raw Rice
- ✦ Boiled Rice
- ✦ Steamed Rice
- ✦ Basmati Rice

Features

- ✦ Accurate structure by advanced laser cutting technology
- ✦ Screens made of galvanized iron will be corrosion free
- ✦ Vibration free

Name : MILLGRAIN RICE SHIFTER

Capacity : 3.0 T / hr

Power : 2 HP

No of Tray : 5 Nos

Voltage : 115 V / 50 Hz

Name : MILLGRAIN RICE SHIFTER

Capacity : 5.0 T/ hr

Power : 3 HP

No of Tray : 5 Nos

Voltage : 115 V / 50 Hz

MILLGRAIN SILKY POLISHER

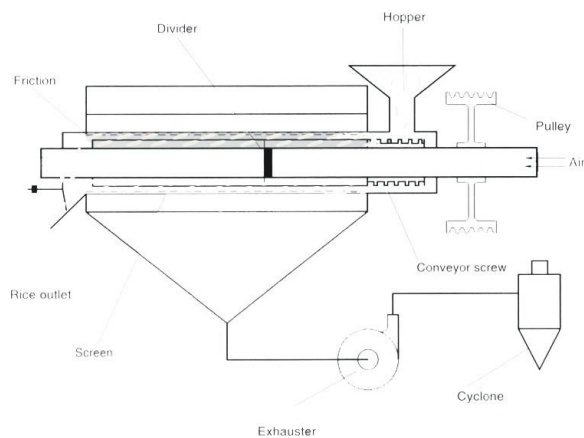

Applications

- ✦ Raw Rice
- ✦ Boiled Rice
- ✦ Steamed Rice
- ✦ Basmati Rice

Features

- ✦ High Degree of glazing due to water jet application
- ✦ Specially designed water jet mechanism
- ✦ Alloy steel feeder and beaters
- ✦ Stainless steel interior of inlet housing to avoid rust

Name : MILLGRAIN SILKY POLISHER

Capacity : 3.5-5 T / hr

Power : 40 / 60 HP

Voltage : 415 V / 50Hz

Aspiration Required : 50 cu. Mt. / min

Special Features : Two / Four Rib Beaters

MILLGRAIN INDENT CYLINDER

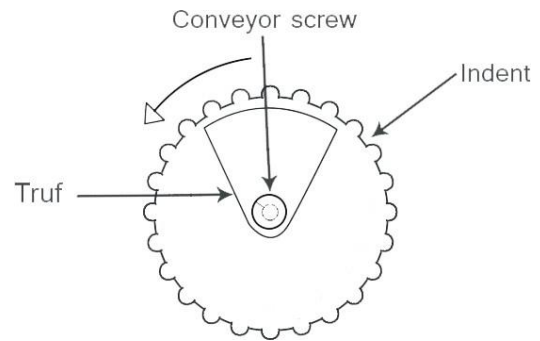

Applications

- ✦ Raw Rice
- ✦ Boiled Rice
- ✦ Steamed Rice
- ✦ Basmati Rice

Features

- ✦ Oscillating tray type
- ✦ Higher output with adjustable speed (optional)

Name	: MILLGRAIN INDENT CYLINDER
Capacity	: 2T Rice/ hr
Power	: 2 HP
Screen Length	: 3150 mm
Screen Dia	: 728 mm
Voltage	: 415 / 50

MILLGRAIN ELAVATOR



Applications

- ✦ Raw Rice
- ✦ Boiled Rice
- ✦ Steamed Rice
- ✦ Basmati Rice

Features

- ✦ The Elevator is used to convey the product vertically. It is effectively used in food Processing industry & bulk storage facilities.
- ✦ The bucket elevator is used in various industries, like rice mills, pulse processing mills feed milling plants.
- ✦ It is equipped with a back stop arrangement to avoid the belt roatating in the wrong direction.
- ✦ Vulcanized rubber pulley to avoid slippage of belt.
- ✦ Shovel type p.p. Buckets & food grade belts are used as standard.

Features

Name : MILLGRAIN ELAVATOR

Capacity : 2-5 T Paddy / hr

Power : 0.75KW - 1.0 HP

Name : MILLGRAIN ELAVATOR

Capacity : 6-8 T Paddy / hr

Power : 1.5KW/2.0 HP



Millgrain Machinery Industries

Reg Off: No. 312, Arani Main Road, Thuthipattu, Vellore-632011, Tamilnadu, India

Mobile: (+91) 8778201289 / (+91) 8105566637

**E-mail: millgrain2000@gmail.com
kumarvinayagam79@gmail.com**

Website: [Www.millgrain.in](http://www.millgrain.in)